



FIRE RATED ACCESS DOORS

DESCRIPTION: CADoors fire rated doors are 20-gauge galvanized steel access doors designed to provide secure and easy access to plumbing, electrical wiring or other utility applications behind walls. Designed for wall and ceiling applications.

Standard Features:

- Door panel is constructed from 20 gauge steel and frame is 16 gauge with a low gloss white prime coated finish
- Fire rating is independently tested for UL listed 1.5 hours “B” label (wall) and 3 hours Warnock-Hersey (ceiling) - max. temperature rise to 250° F in 30 minutes
- Two inch thick fire-rated mineral fiber R-8 insulation
- Easy to operate knurled knob key operated latch release and self closing door
- Flush continuous piano hinge
- Other sizes available upon request

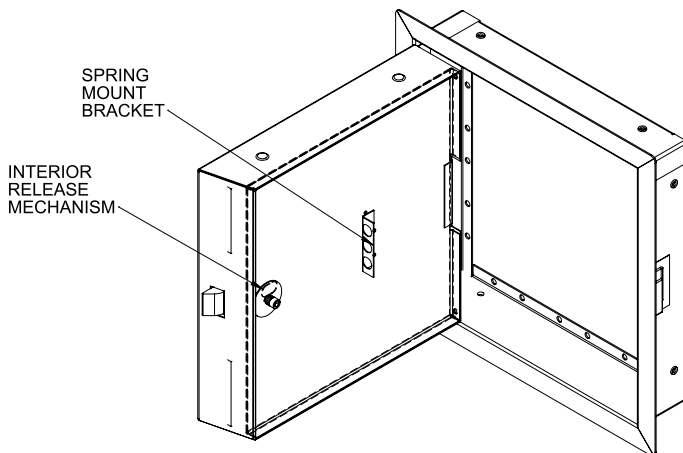
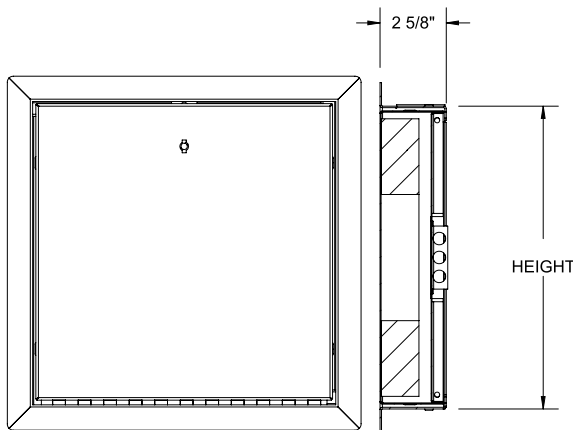

FIRE RATED PRIMER COATED DOORS		
PART #	SIZE	LATCH
FR 8.8. RTL	8" x 8"	Knurled Knob Key Operated Latch Release
FR 12.12 RTL	12" x 12"	Knurled Knob Key Operated Latch Release
FR 14.14 RTL	14" x 14"	Knurled Knob Key Operated Latch Release
FR 16.16 RTL	16" x 16"	Knurled Knob Key Operated Latch Release
FR 18.18 RTL	18" x 18"	Knurled Knob Key Operated Latch Release
FR 24.24 RTL	24" x 24"	Knurled Knob Key Operated Latch Release

Measurements are subject to manufacturing tolerances and may change without notice. CommercialAccessDoors® maintains the right to modify or change the product's design or construction without prior notice and without incurring any obligation to make similar changes and modifications to any product previously sold. Contact a CommercialAccessDoors® representative for clarifications.

